



Demolition grabs

**HYDRAULIC
HAMMERS**



SHEET PILERS



STEEL SHEARS



X-Y-Z CONCEPT



COMPACTORS



CRUNCHERS



CRUSHERS



**DEMOLITION
GRABS**



**MULTI-
PROCESSORS**



Dealer:

NPK Europe (Holland) BV

P. O. Box 30157
3001 DD Rotterdam
The Netherlands
Tel: +31 10 205 1710
Fax: +31 10 205 1715
E-mail: info@npke.nl

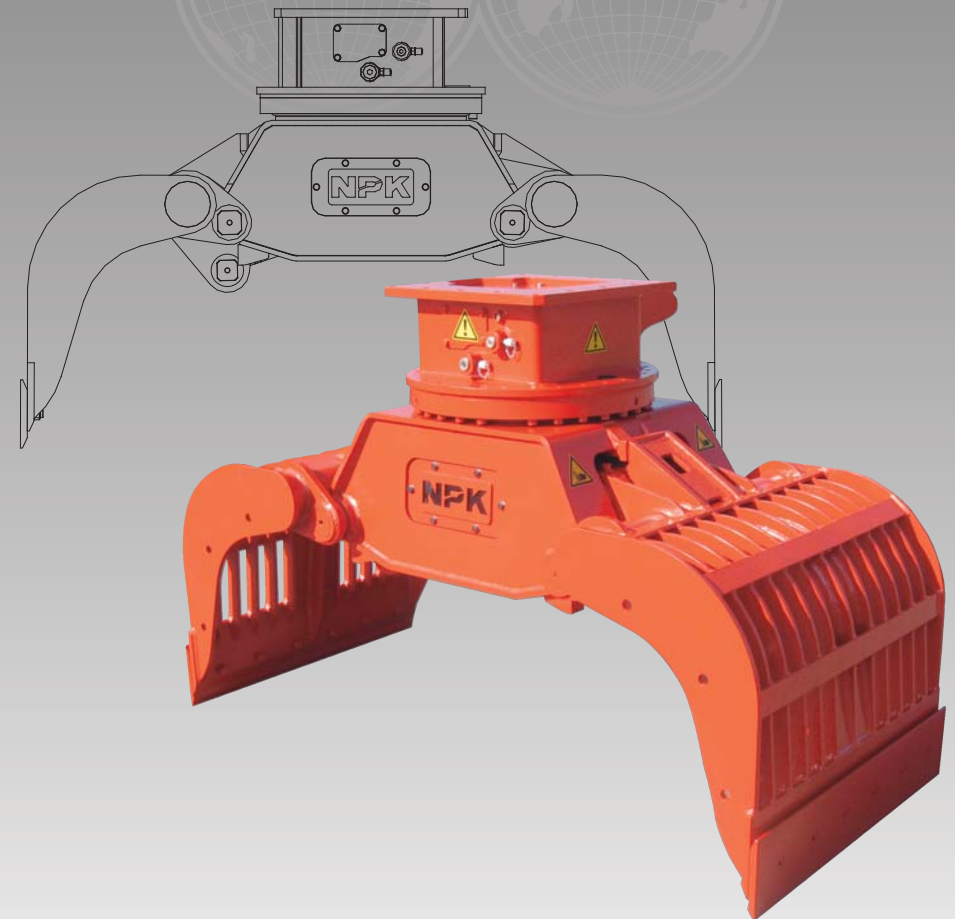

Demolition, recycling, loading...

NPK demolition and dismantling grabs are versatile, 360° hydraulically rotatable, attachments manufactured from wear resistant steel alloy. The grabs of the DG-series allow reduced operation costs for demolition, dismantling, loading, sorting and recycling applications.

Specialist hardening processes and welding procedures, along with heavy duty components, guarantee superb quality and a long life. To add to these features only the best hydraulic components, which have been fully protected within the design, are used. As with other NPK attachments these grabs offer an excellent return on investment.

The DG-4, DG-6 and DG-9 are equipped with an hydraulic rotator, offering a compact solution, also giving less and easier maintenance with high durability. Its speed is unaffected by varying oil flows (12 - 40 l/min). The DG-14, DG-16, DG-20, DG-30 and DG-40 are manufactured with a high quality bearing. All grabs have a flat top fixing, making it simple to use any bolt-on adaptor bracket, matching the mechanical/hydraulic quick hitch or directly to any brand of excavator.

Clam cutters are interchangeable and as an option, side covers are available for loading activities.

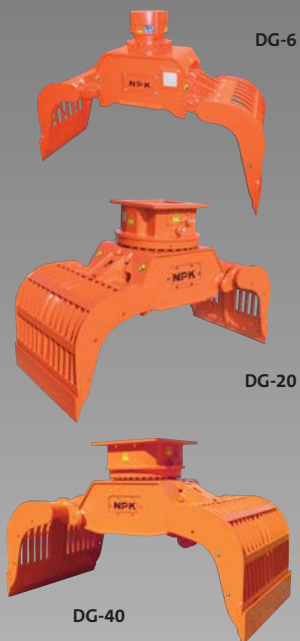

FEATURES

- Fully protected hydraulic components.
- Interchangeable clam cutters. (HB500)
- Frame made of high strength steel/HARDOX
- 360° Hydraulic rotation, no drain line required.
- Large straight jaw opening.
- Easy maintenance.
- In one position greaseable.
- Replaceable pin bushings.
- Low cost, high efficiency.
- Cage construction of the jaws, made of HARDOX 400.
- Main pins equipped with dust seals.
- High closing force.
- Double shock valve protects motor (DG-14, DG-16, DG-20, DG-30 and DG-40).
- Pilot check valve standard from DG-14 and up.
- One powerful cylinder.

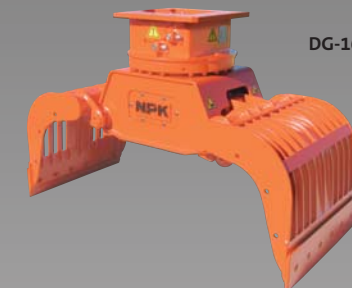

TECHNICAL SPECIFICATIONS

Model	DG-4	DG-6	DG-9	DG-14	DG-16	DG-20	DG-30	DG-40
Excavator weight (t)	2,5 - 4	4 - 6	5 - 9	7 - 14	10 - 16	14 - 20	18 - 30	25 - 40
Weight (kg)	200	305	425	635	860	1150	1750	2050
Capacity (L)	90	150	180	300	425	500	800	900
Working pressure (MPa)	18 - 26	18 - 28	22 - 32	25 - 35	25 - 35	25 - 35	25 - 35	25 - 35
Oil flow (l/min)	15 - 35	20 - 40	30 - 50	30 - 60	60 - 100	60 - 100	80 - 120	80 - 120
Closing force (kN)	15	21	32	38	48	52	72	72
Rotation:								
Working pressure (MPa)	18 - 26	20 - 28	22 - 32	10 - 14	10 - 14	10 - 14	10 - 14	10 - 14
Oil flow (l/min)	12 - 22	15 - 25	18 - 25	20 - 30	20 - 30	20 - 30	20 - 30	20 - 30
Dimensions:								
A (mm)	1145	1355	1632	1800	1850	2050	2410	2410
B (mm)	790	935	1035	1175	1200	1285	1470	1470
Width (mm)	450	500	580	700	860	950	1115	1360

Specifications subject to change without prior notice

